

N240

Sizes 2" – 24"



Description

This heavy-duty globe valve complies with API and BS standards. The seat ring and wedge disc are precision-ground and lapped to achieve mirror-like finishes, ensuring optimal sealing surfaces. A plug-type disc is standard, with flat and regulating discs available upon request.

The heat-treated stainless steel stem features precision-machined ACME threads for extended service life. A machined backseat bushing provides a secondary metal-to-metal stem seal. The rising stem clearly indicates the valve's open/closed position, and the large-diameter handwheel allows for easy operation.

The yoke sleeve is constructed from austenitic ductile iron, offering excellent resistance to heat, corrosion, and wear. A two-piece, self-aligning gland bushing and gland flange prevent damage, reinforced by high-strength alloy steel stud bolts.

Design: API 600

Shell Thickness: API 600

Flanged Ends: ANSI B16.5

Face to Face: ANSI B16.10

Testung: API 598

Gate Valve API 600 ANSI Class 150-2500

-
- **API 600, API 602, MSS SP-53**
- **Bolted bonnet and Union Bonnet**
- **Gate type: Parallel Gate or Wedge Gate**
- **Hand and Gear Wheel Operated (Actuation Available)**
- **Flanged, Threaded or Butt-welded**
- **Body: cast and forging form**
- **Flange design (ASME B16.5), weld end or weld-in end**



Beschreibung

Konstruiert nach API 600 und druckgeprüft gemäß API 598/EN 12266-1, bietet dieses robuste Flansch-Absperrventil hervorragende Langlebigkeit für anspruchsvolle industrielle Anwendungen, Kesselanlagen und raue Umgebungen. Das Ventil ist mit ANSI 150 Flanschen erhältlich und gewährleistet durch ein robustes Handrad eine maximale Lebensdauer.



Description

Designed to API 600 and pressure tested according to API 598/EN 12266-1, this robust flanged gate valve offers exceptional durability for demanding industrial applications, boiler systems, and harsh environments. Available with ANSI 150 flanges, the valve ensures maximum service life through a sturdy handwheel.

For information please contact us:
info@newcomen.de
(+49) 21511528392

Gate Valve API 600 ANSI Class 150-2500

N.E.V

Newcomen Engineering Valve

- Gate Valve API 600 ANSI Class 150 to 2500
- Bolted bonnet and Union Bonnet
- Outside Screw and Yoke, Rising stem
- Hand and Gear Wheel Operated (Actuation Available)
- Body: cast and forging form
- Gate type: Parallel Gate or Wedge Gate

Description of Parts	
1	Body
2	Bonnet
3	Wedge Disc
4	Seat Ring
5	Stem
6	Backseat Bushing
7	Gland Bushing
8	Gland Flange
9	Packing
10	Gasket
11	Yoke Sleeve
12	Retainer Sleeve
13	Hand wheel
14	Hand wheel Nut
15/16	Stud Bolt / Hex Nut
17	Eyebolt
18	Pin
19	Hex Nut
21	Grease Fitting

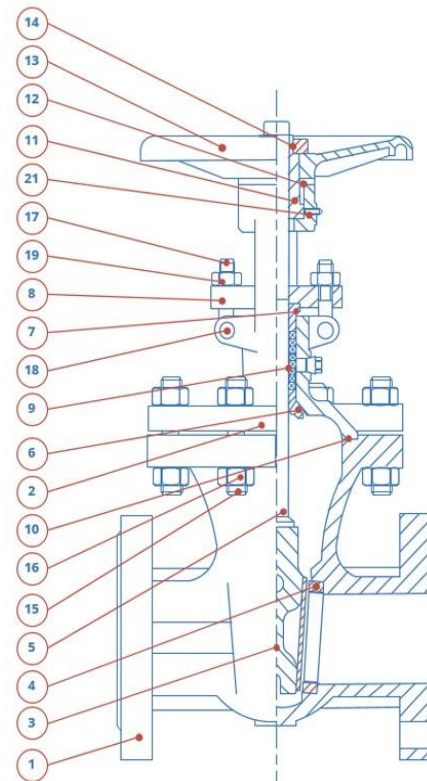

Material Structure

Part	ANSI B16.34				
	Carbon Steel	Carbon-Manganese steel	Alloy Steel		
Body / Bonnet	A216 WCB	A352 LCC	A217 WC6	A217 WC9	A217 C5
Gland Bushing	13% Chromium ASTM A182 Gr.F6a				
Stud Bolt & Hex Nuts	B7 / 2H	L7/7	ASTM A193 Gr B16		
Yoke/Gland Flange	Carbon Steel				
Yoke Sleeve	ASTM A439 Type D2				
Retainer Nut	Carbon Steel				
Hand wheel	Cast Iron				
Hand Wheel Nut	Carbon Steel				
Gland Eyebolts & Nut	ASTM A307 Gr.B				

Part	Corrosion Resistant Steel				
Body / Bonnet	A351 CF8	A351 CF3	A351 CF8M	A351 CF3M	A351 CN7M
Gland Bushing	304 SS	304 SS	316 SS	316L SS	Alloy 20
Stud Bolt & Hex Nuts	ASTM 193 Gr.B8 / ASTM A194 Gr.8				
Yoke/Gland Flange	ASTM 193 Gr.B8				
Yoke Sleeve	ASTM A439 Type D2				
Retainer Nut	Carbon Steel				
Hand wheel	Cast Iron				
Hand Wheel Nut	Carbon Steel				
Gland Eyebolts & Nut	ASTM A193 Gr.B8				

Trim Material

Part	API Trim Number										
	1	2	5	8	9	10	11	12	13	14	15
Disc	F6	304SS	HF	F6	Ni-CU	316SS	Ni-CU	316SS	Alloy 20	Alloy 20	HF
Seat Ring	F6	304SS	HF	HF	Ni-CU	316SS	HF	HF	Alloy 20	HF	HF
Stem	F6	304SS	F6	F6	Ni-CU	316SS	Ni-CU	316SS	Alloy 20	Alloy 20	304SS
Backseat	F6	304SS	F6	F6	Ni-CU	316SS	Ni-CU	316SS	Alloy 20	Alloy 20	304SS
Washer / Nut	F6	304SS	F6	F6	Ni-CU	316SS	Ni-CU	316SS	Alloy 20	Alloy 20	304SS

Gate Valve API 600 ANSI Class 150-2500

N.E.V

Newcomen Engineering Valve

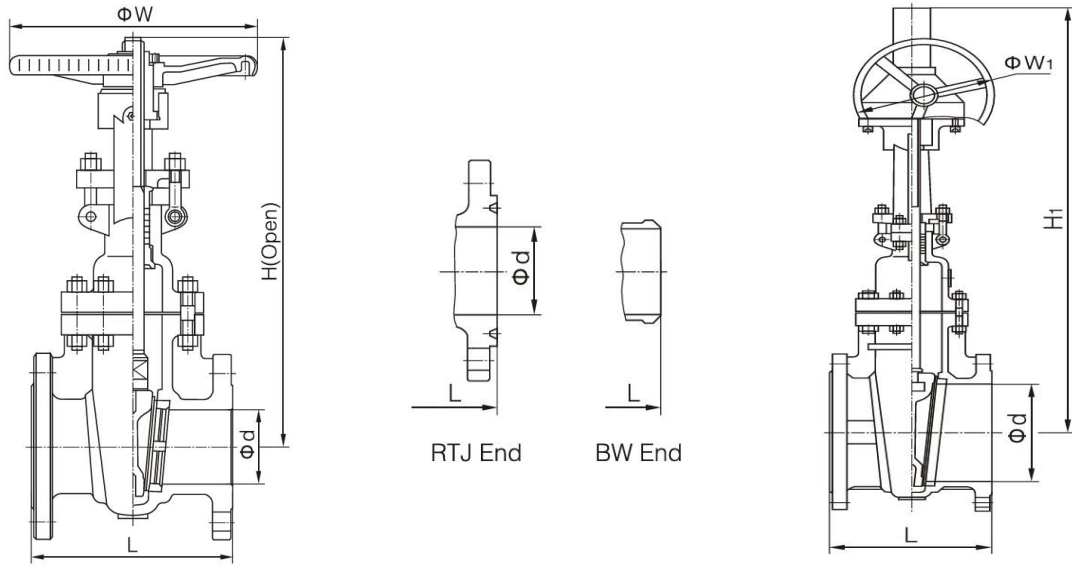

Gate Valve 150 LBS

Part		2	4	6	8	10	12	14	16	18	20	24
L:mm	RF	178	229	267	292	330	356	381	406	432	457	508
	RTG	191	241	305	305	343	368	394	419	445	470	521
	BW	216	279	403	419	457	502	572	610	660	711	813
d:mm		51	102	152	203	254	305	337	387	438	489	591
H:mm		400	595	780	975	1150	-	-	-	-	-	-
H1:mm		-	-	-	-	1200	1413	1580	1733	1990	2220	2600
W:mm		200	280	300	350	400	-	-	-	-	-	-
W1:mm		-	-	-	-	310	310	310	460	460	460	460
Weight:KG		19	49	78	125	190	290	386	500	600	763	1010
Weight:KG (GO)		-	-	-	-	220	315	437	555	654	819	1186

- Above 10 inches (DN 250): Gear wheels are recommended to reduce operating effort and improve safety, as the torque required to open or close the valve increases significantly with size.
- For sizes 16 inches (DN 400) and larger, motorized or hydraulic actuators might be considered instead of manual gear wheels, depending on the specific application and required operating frequency.

Gate Valve 300 LBS

Part		2	4	6	8	10	12	14	16	18	20	24
L:mm	RF	216	305	403	419	457	502	762	838	914	991	1143
	RTG	232	321	419	435	473	518	778	854	930	1010	1165
	BW	216	305	403	419	457	502	762	838	914	991	1143
d:mm		51	102	152	203	254	305	337	387	438	489	591
H:mm		420	619	806	1000	1240	1425	1585	1790	1960	2158	2576
H1:mm		-	-	-	1030	1280	1460	1620	1830	2000	2220	2620
W:mm		200	280	350	400	-	-	-	-	-	-	-
W1:mm		-	-	-	310	310	310	460	460	460	460	600
Weight:KG		25	73	130	208	-	-	-	-	-	-	-
Weight:KG (GO)		-	-	-	236	387	505	756	967	1225	1398	2386

- Above 6 inches (DN 150): Gear wheels are recommended to reduce operating effort and improve safety, as the torque required to open or close the valve increases significantly with size.
- For sizes 16 inches (DN 400) and larger, motorized or hydraulic actuators might be considered instead of manual gear wheels, depending on the specific application and required operating frequency.

Gate Valve 600 LBS

Part		2	4	6	8	10	12	14	16	18	20	24
L:mm	RF	292	432	559	660	787	838	889	991	1092	1194	1398
	RTG	295	435	562	664	791	841	892	994	1095	1200	1407
	BW	292	432	559	660	787	838	889	991	1092	1194	1397
d:mm		51	102	152	203	254	305	337	387	438	489	591
H:mm		444	665	868	1073	1263	1600	1705	1835	-	-	-
H1:mm		-	-	900	1110	1300	1650	1750	1900	2020	2172	2650
W:mm		200	300	450	-	-	-	-	-	-	-	-
W1:mm		-	-	310	310	460	460	460	460	600	600	600
Weight:KG		33	110	220	-	-	-	-	-	-	-	-
Weight:KG (GO)		-	-	270	450	660	895	1330	1570	1980	2465	3655

- Above 6 inches (DN 150): Gear wheels are recommended to reduce operating effort and improve safety, as the torque required to open or close the valve increases significantly with size.
- For sizes 12 inches (DN 300) and larger, motorized or hydraulic actuators might be considered instead of manual gear wheels, depending on the specific application and required operating frequency.

Gate Valve 900 LBS

Part		2	4	6	8	10	12	14
L:mm	RF	368	457	610	737	838	965	1029
	RTG	371	460	613	740	841	968	1038
	BW	368	457	610	737	838	965	1029
d:mm		51	102	152	203	254	305	322
H:mm		500	-	-	-	-	-	-
H1:mm		-	750	1060	1140	1370	1620	2020
W:mm		280	-	-	-	-	-	-
W1:mm		-	310	460	460	460	460	600
Weight:KG		70	-	-	-	-	-	-
Weight:KG (GO)		-	230	415	610	1110	1330	1710

- Gear wheels are recommended for 3 inches and above to handle the high torque requirements effectively,
- For sizes 12 inches (DN 300) and larger, it might even have considered motorized or hydraulic actuators instead of manual gear wheels, depending on the specific application and operational frequency.

Gate Valve API 600 ANSI Class 150-2500

N.E.V

Newcomen Engineering Valve

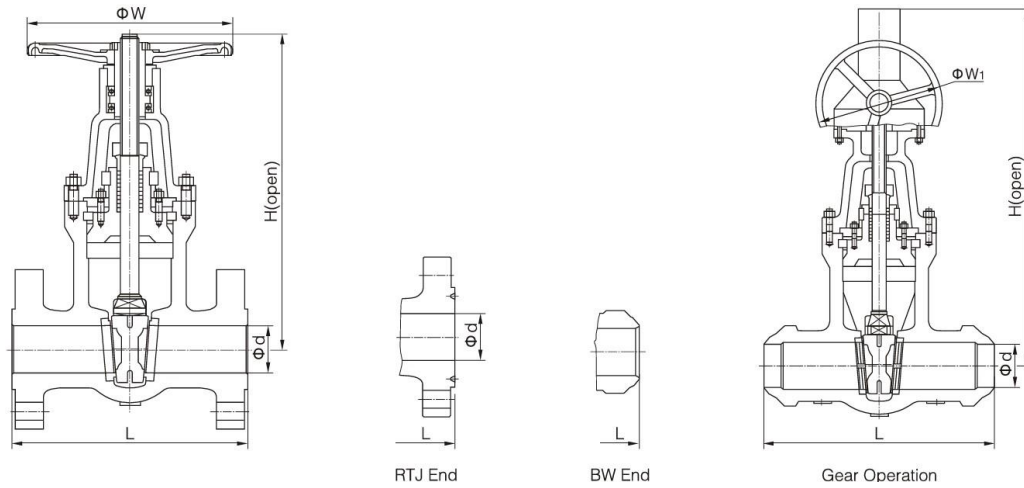

Gate Valve 1500 LBS

Part		2	4	6	8	10	12	14
L:mm	RF	368	546	705	832	991	1130	1257
	RTG	371	549	711	841	1000	1146	1276
	BW	368	546	705	832	991	1130	1257
d:mm		51	102	144	192	239	287	315
H:mm		510	-	-	-	-	-	-
H1:mm		560	770	1070	1180	1410	1620	2020
W:mm		280	400	500	750	900	-	-
W1:mm		260	310	460	460	600	600	600
Weight:KG		68	-	-	-	-	-	-
Weight:KG (GO)		104	310	580	920	1760	2125	2620

- Gear wheels are recommended for 2 inches and above to handle the high torque requirements effectively,
- For sizes 6 inches (DN 150) and larger, it might even have considered motorized or hydraulic actuators instead of manual gear wheels, depending on the specific application and operational frequency.
Specific data sheets for valves with actuators will be provided upon request.

Gate Valve 2500 LBS

Part		2	4	6	8	10	12
L:mm	RF	541	673	914	1022	1270	1422
	RTG	454	683	927	1038	1292	1445
	BW	451	673	914	1022	1270	1422
d:mm		42	87	131	179	223	265
H:mm		530	-	-	-	-	-
H1:mm		580	800	1100	1200	1460	1660
W:mm		280	-	-	-	-	-
W1:mm		310	310	460	460	600	600
Weight:KG		100	-	-	-	-	-
Weight:KG (GO)		130	430	840	1355	2570	3250

- Gear wheels are recommended for 2 inches and above to handle the high torque requirements effectively,
- For sizes 6 inches (DN 150) and larger, it might even have considered motorized or hydraulic actuators instead of manual gear wheels, depending on the specific application and operational frequency.
Specific data sheets for valves with actuators will be provided upon request.